

Artwork Specification – 3x1 Curved Pop Up Display Stand

Artwork should be provided as a high resolution PDF to the following specification

- CMYK colour profile
- Vector format/ 300dpi or higher
- Text outlined
- Images linked/embedded
- Layers flattened

No bleed or crop marks required

Artwork should be supplied at full size or 25% of the total artwork size as a complete document

3x1 Curved Pop Up Stand: 3 Panels = 1 x front panel and 2 x 'D' end wraparound panels

Total Artwork size: 2019mm (W) x 2225mm (H)

25% Artwork size: 504.75mm (W) x 556.25mm (H)

Front panels = 673mm/168.25mm (25%) | 'D' End panel = 673mm/168.25mm (25%)

Please position any text, images or logos used on the 'D' end panels within the side and front sections of the panel avoiding the grey chevron area, as indicated on the diagram.

[Watch our 'how to design artwork' video here](#)

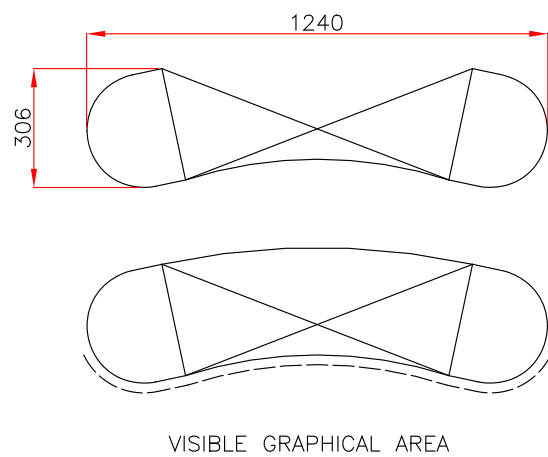
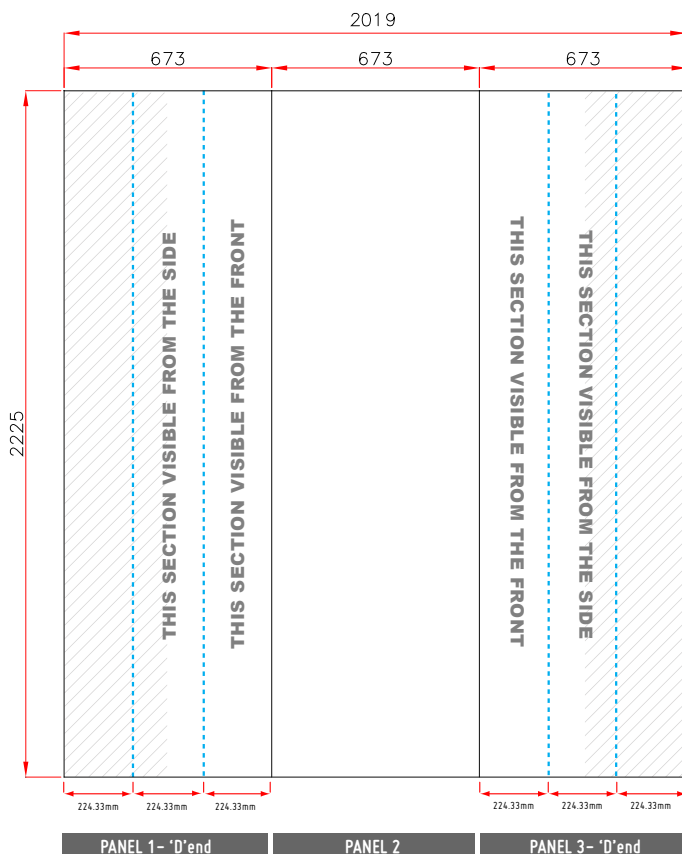

The viewing distance for pop-up displays will be app 3m, but at least 1m
According to the file format, colour anomalies may occur

We print with a tolerance of 0.1 to 0.2% so a difference of 1mm up to 5mm is normal within a height of 230cm

Artwork Specification – 3x1 Straight Pop Up Display Stand

Artwork should be provided as a high resolution PDF to the following specification

- CMYK colour profile
- Vector format/ 300dpi or higher
- Text outlined
- Images linked/embedded
- Layers flattened

No bleed or crop marks required

Artwork should be supplied at full size or 25% of the total artwork size as a complete document

3x1 Straight Pop Up Stand: 3 Panels = 1 x front panel and 2 x 'D' end wraparound panels

Total Artwork size: 2078mm (W) x 2225mm (H)

25% Artwork size: 519.50mm (W) x 556.25mm (H)

Front panel = 732mm/183mm (25%) | 'D' End panel = 673mm/168.25mm (25%)

Please position any text, images or logos used on the 'D' end panels within the side and front sections of the panel avoiding the grey chevron area, as indicated on the diagram.

[Watch our 'how to design artwork' video here](#)

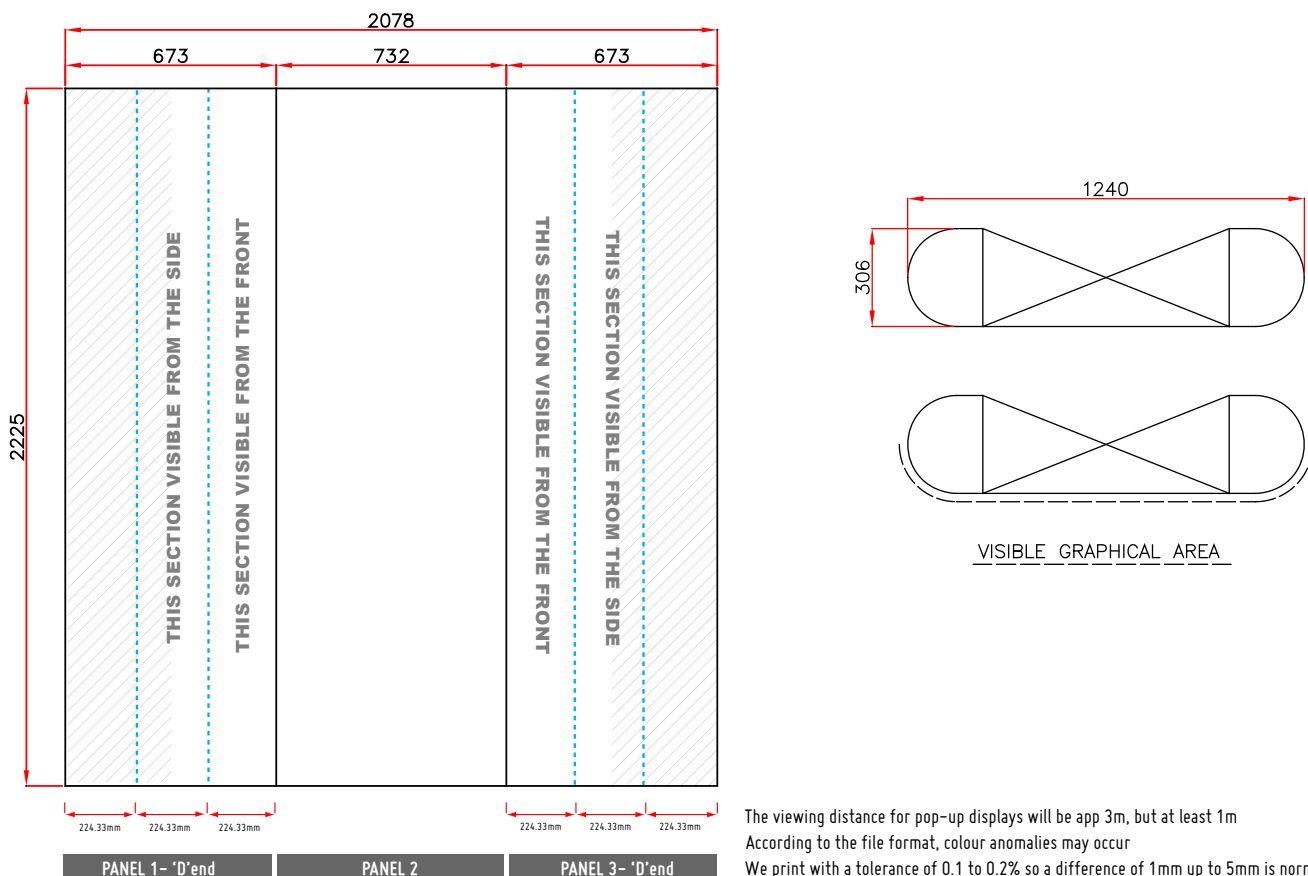

The viewing distance for pop-up displays will be app 3m, but at least 1m

According to the file format, colour anomalies may occur

We print with a tolerance of 0.1 to 0.2% so a difference of 1mm up to 5mm is normal within a height of 230cm

Artwork Specification – 3x2 Curved Pop Up Display Stand

Artwork should be provided as a high resolution PDF to the following specification

- CMYK colour profile
- Vector format/ 300dpi or higher
- Text outlined
- Images linked/embedded
- Layers flattened

No bleed or crop marks required

Artwork should be supplied at full size or 25% of the total artwork size as a complete document

3x2 Curved Pop Up Stand: 4 Panels = 2 x front panel and 2 x 'D' end wraparound panels

Total Artwork size: 2692mm (W) x 2225mm (H)

25% Artwork size: 673mm (W) x 556.25mm (H)

Front panels = 673mm/168.25mm (25%) | 'D' End panel = 673mm/168.25mm (25%)

Please position any text, images or logos used on the 'D' end panels within the side and front sections of the panel avoiding the grey chevron area, as indicated on the diagram.

[Watch our 'how to design artwork' video here](#)

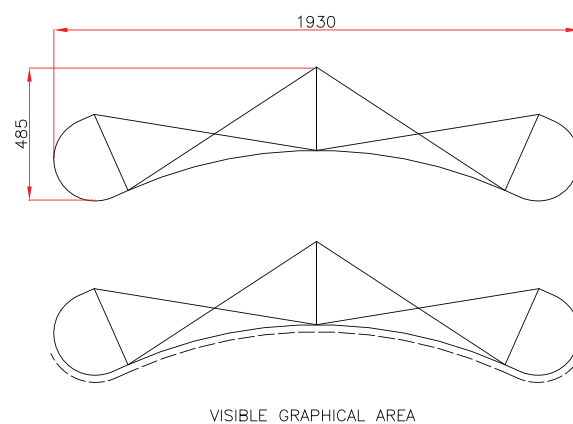
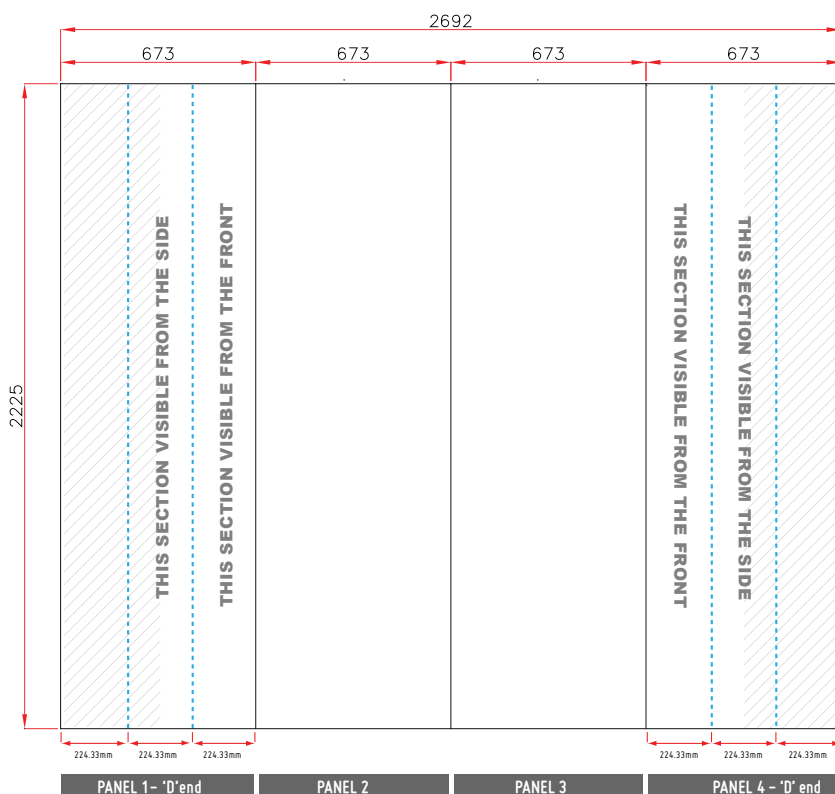

The viewing distance for pop-up displays will be app 3m, but at least 1m
 According to the file format, colour anomalies may occur
 We print with a tolerance of 0.1 to 0.2% so a difference of 1mm up to 5mm is normal within a height of 230cm

Artwork Specification – 3x2 Straight Pop Up Display Stand

Artwork should be provided as a high resolution PDF to the following specification

- CMYK colour profile
- Vector format/ 300dpi or higher
- Text outlined
- Images linked/embedded
- Layers flattened

No bleed or crop marks required

Artwork should be supplied at full size or 25% of the total artwork size as a complete document

3x2 Straight Pop Up Stand: 4 Panels = 2 x front panel and 2 x 'D' end wraparound panels

Total Artwork size: 2810mm (W) x 2225mm (H)

25% Artwork size: 702.50mm (W) x 556.25mm (H)

Front panel = 732mm/183mm (25%) | 'D' End panel = 673mm/168.25mm (25%)

Please position any text, images or logos used on the 'D' end panels within the side and front sections of the panel avoiding the grey chevron area, as indicated on the diagram.

[Watch our 'how to design artwork' video here](#)

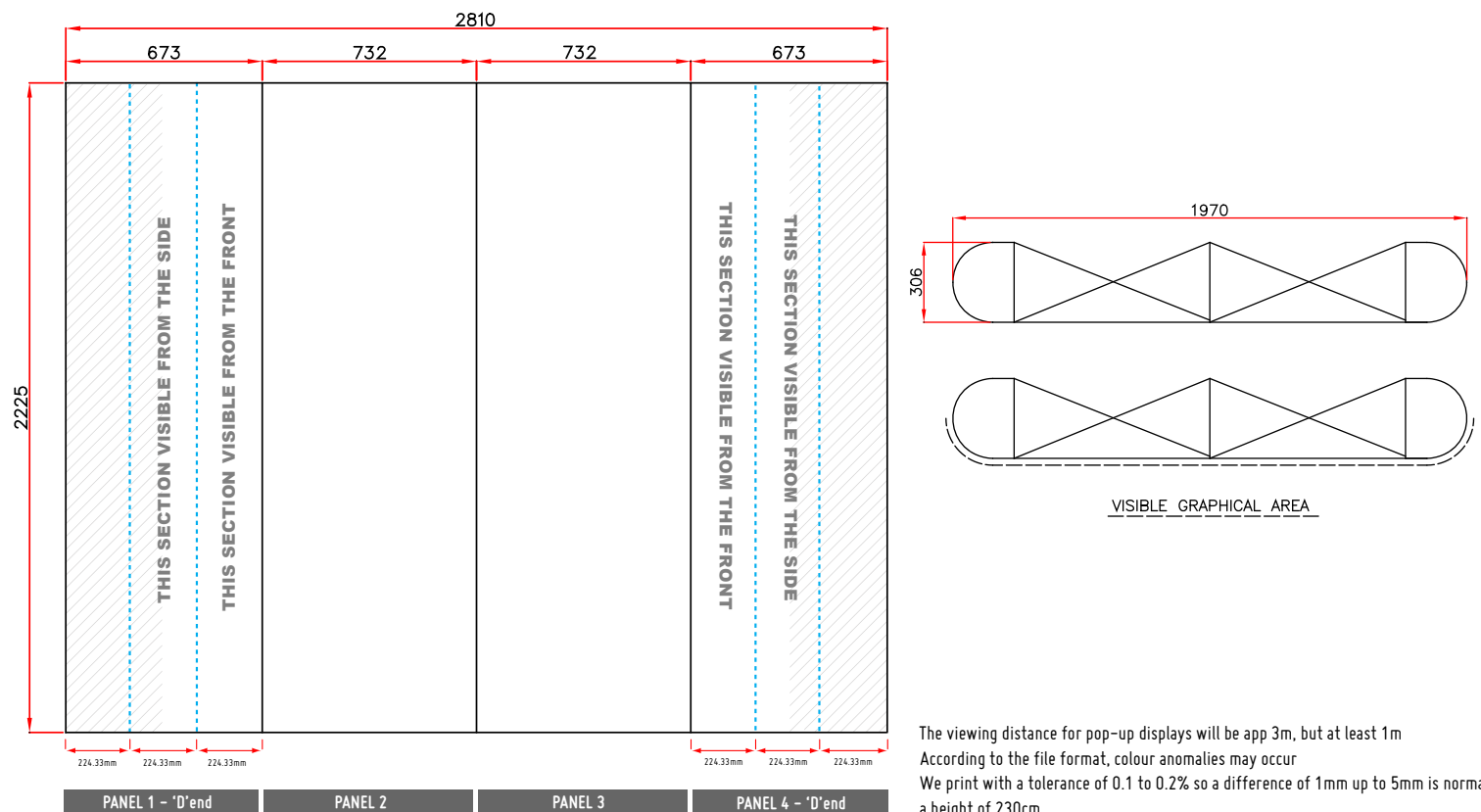

The viewing distance for pop-up displays will be app 3m, but at least 1m
 According to the file format, colour anomalies may occur
 We print with a tolerance of 0.1 to 0.2% so a difference of 1mm up to 5mm is normal within
 a height of 230cm

Artwork Specification – 3x3 Curved Pop Up Display Stand

Artwork should be provided as a high resolution PDF to the following specification

- CMYK colour profile
- Vector format/ 300dpi or higher
- Text outlined
- Images linked/embedded
- Layers flattened

No bleed or crop marks required

Artwork should be supplied at full size or 25% of the total artwork size as a complete document

3x3 Curved Pop Up Stand: 5 Panels = 3 x front panel and 2 x 'D' end wraparound panels

Total Artwork size: 3365mm (W) x 2225mm (H)

25% Artwork size: 841.25mm (W) x 556.25mm (H)

Front panels = 673mm/168.25mm (25%) | 'D' End panel = 673mm/168.25mm (25%)

Please position any text, images or logos used on the 'D' end panels within the side and front sections of the panel avoiding the grey chevron area, as indicated on the diagram.

[Watch our 'how to design artwork' video here](#)

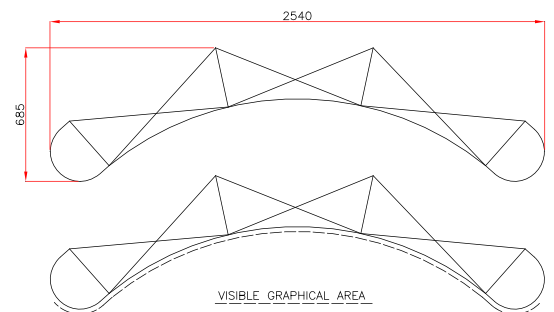
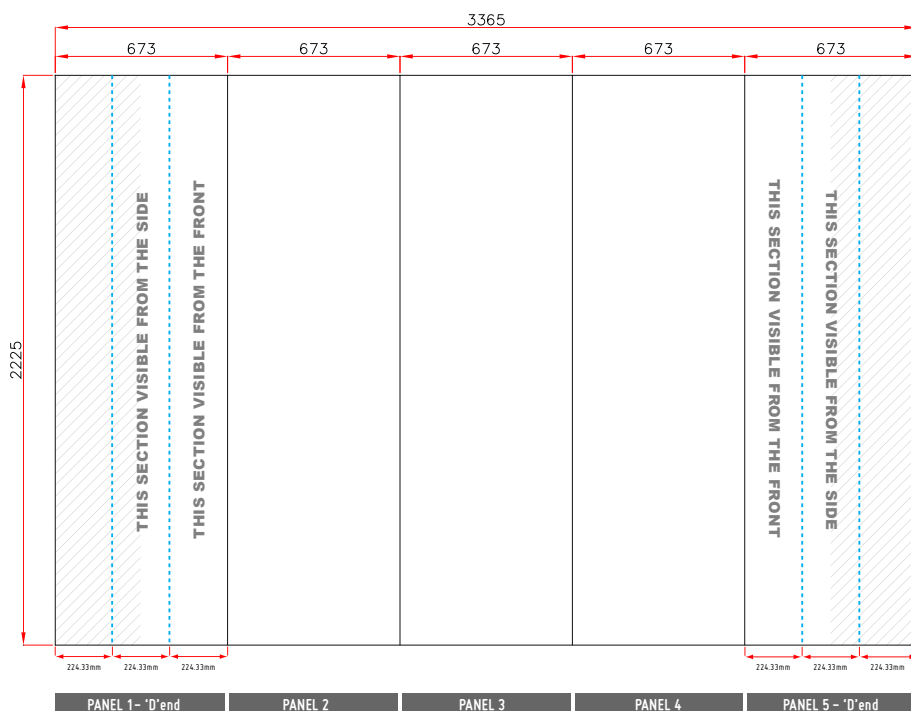

The viewing distance for pop-up displays will be app 3m, but at least 1m
According to the file format, colour anomalies may occur

We print with a tolerance of 0.1 to 0.2% so a difference of 1mm up to 5mm is normal within a height of 230cm

Artwork Specification – 3x3 Straight Pop Up Display Stand

Artwork should be provided as a high resolution PDF to the following specification

- CMYK colour profile
- Vector format/ 300dpi or higher
- Text outlined
- Images linked/embedded
- Layers flattened

No bleed or crop marks required

Artwork should be supplied at full size or 25% of the total artwork size as a complete document

3x3 Straight Pop Up Stand: 5 Panels = 3 x front panel and 2 x 'D' end wraparound panels

Total Artwork size: 3542mm (W) x 2225mm (H)

25% Artwork size: 885.50mm (W) x 556.25mm (H)

Front panel = 732mm/183mm (25%) | 'D' End panel = 673mm/168.25mm (25%)

Please position any text, images or logos used on the 'D' end panels within the side and front sections of the panel avoiding the grey chevron area, as indicated on the diagram.

[Watch our 'how to design artwork' video here](#)

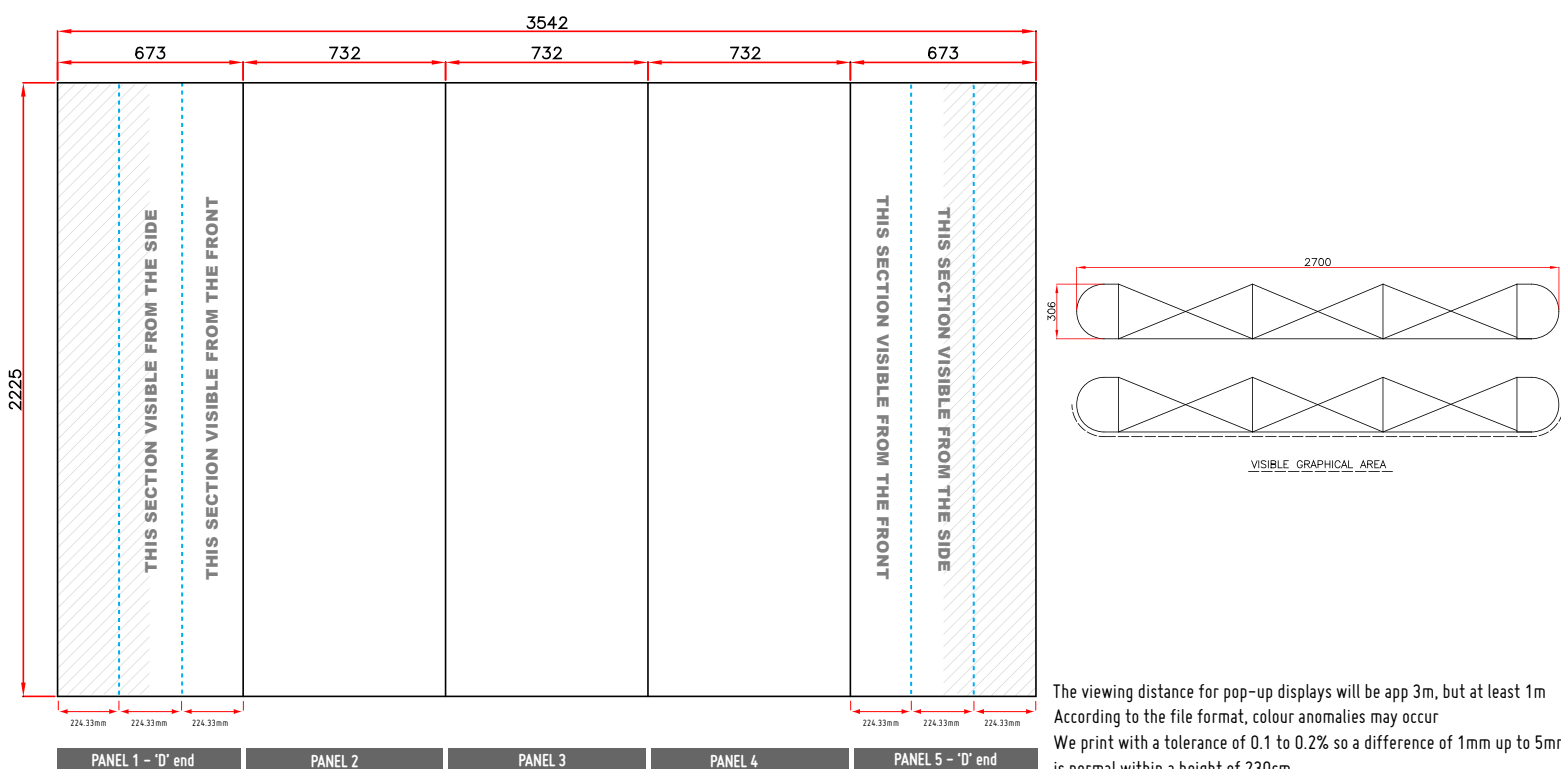

The viewing distance for pop-up displays will be app 3m, but at least 1m
According to the file format, colour anomalies may occur
We print with a tolerance of 0.1 to 0.2% so a difference of 1mm up to 5mm
is normal within a height of 230cm

Artwork Specification – 3x4 Curved Pop Up Display Stand

Artwork should be provided as a high resolution PDF to the following specification

- CMYK colour profile
- Vector format/ 300dpi or higher
- Text outlined
- Images linked/embedded
- Layers flattened

No bleed or crop marks required

Artwork should be supplied at full size or 25% of the total artwork size as a complete document

3x4 Curved Pop Up Stand: 6 Panels = 4 x front panel and 2 x 'D' end wraparound panels

Total Artwork size: 4038mm (W) x 2225mm (H)

25% Artwork size: 1009.5mm (W) x 556.25mm (H)

Front panels = 673mm/168.25mm (25%) | 'D' End panel = 673mm/168.25mm (25%)

Please position any text, images or logos used on the 'D' end panels within the side and front sections of the panel avoiding the grey chevron area, as indicated on the diagram.

Watch our ['how to design artwork' video here](#)

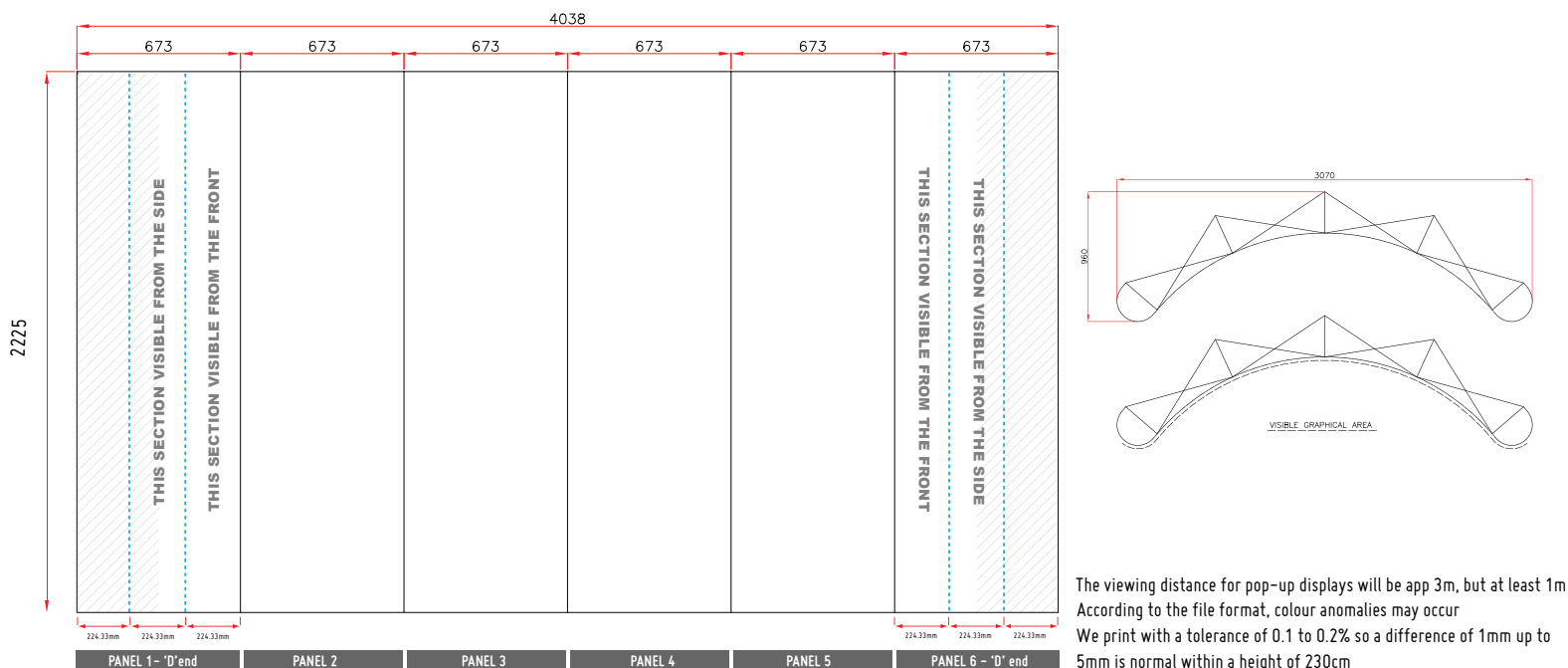

Artwork Specification – 3x4 Straight Pop Up Display Stand

Artwork should be provided as a high resolution PDF to the following specification

- CMYK colour profile
- Vector format/ 300dpi or higher
- Text outlined
- Images linked/embedded
- Layers flattened

No bleed or crop marks required

Artwork should be supplied at full size or 25% of the total artwork size as a complete document

3x4 Straight Pop Up Stand: 6 Panels = 4 x front panel and 2 x 'D' end wraparound panels

Total Artwork size: 4275mm (W) x 2225mm (H)

25% Artwork size: 1068.75mm (W) x 556.25mm (H)

Front panel = 732mm/183mm (25%) | 'D' End panel = 673mm/168.25mm (25%)

Please position any text, images or logos used on the 'D' end panels within the side and front sections of the panel avoiding the grey chevron area, as indicated on the diagram.

[Watch our 'how to design artwork' video here](#)

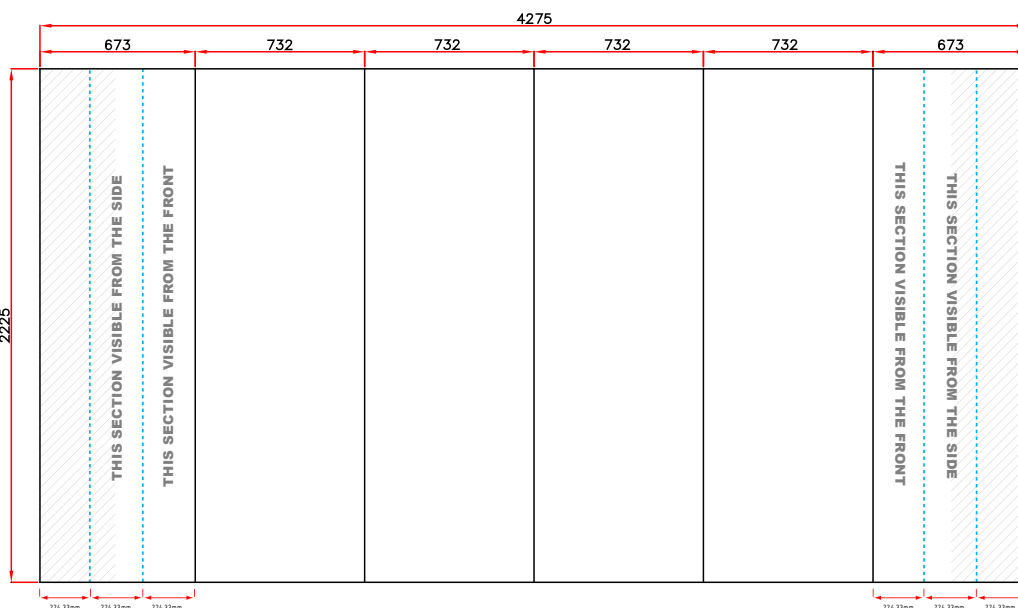
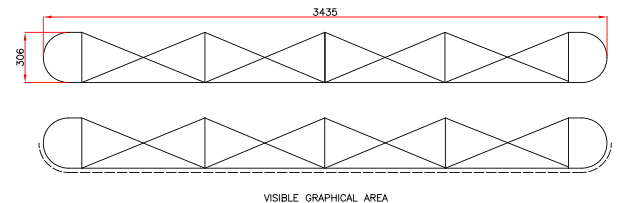

PANEL 1 – 'D' end PANEL 2 PANEL 3 PANEL 4 PANEL 5 PANEL 6 – 'D' end

The viewing distance for pop-up displays will be app 3m, but at least 1m
 According to the file format, colour anomalies may occur
 We print with a tolerance of 0.1 to 0.2% so a difference of 1mm up to 5mm
 is normal within a height of 230cm

Artwork Specification – 3x5 Curved Pop Up Display Stand

Artwork should be provided as a high resolution PDF to the following specification

- CMYK colour profile
- Vector format/ 300dpi or higher
- Text outlined
- Images linked/embedded
- Layers flattened

No bleed or crop marks required

Artwork should be supplied at full size or 25% of the total artwork size as a complete document

3x5 Curved Pop Up Stand: 7 Panels = 5 x front panel and 2 x 'D' end wraparound panels

Total Artwork size: 4711mm (W) x 2225mm (H)

25% Artwork size: 1177.75mm (W) x 556.25mm (H)

Front panels = 673mm/168.25mm (25%) | 'D' End panel = 673mm/168.25mm (25%)

Please position any text, images or logos used on the 'D' end panels within the side and front sections of the panel avoiding the grey chevron area, as indicated on the diagram.

[Watch our 'how to design artwork' video here](#)

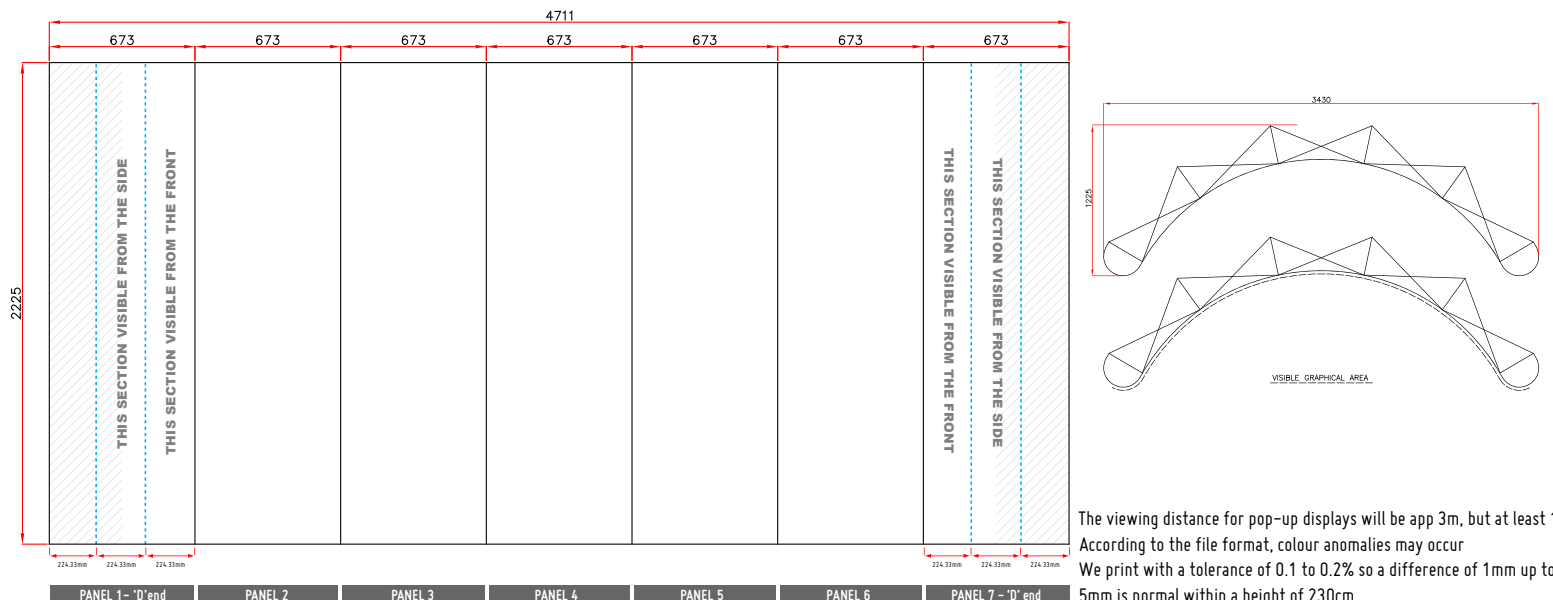

The viewing distance for pop-up displays will be app 3m, but at least 1m
According to the file format, colour anomalies may occur
We print with a tolerance of 0.1 to 0.2% so a difference of 1mm up to 5mm is normal within a height of 230cm

Artwork Specification – 3x5 Straight Pop Up Display Stand

Artwork should be provided as a high resolution PDF to the following specification

- CMYK colour profile
- Vector format/ 300dpi or higher
- Text outlined
- Images linked/embedded
- Layers flattened

No bleed or crop marks required

Artwork should be supplied at full size or 25% of the total artwork size as a complete document

3x5 Straight Pop Up Stand: 7 Panels = 5 x front panel and 2 x 'D' end wraparound panels

Total Artwork size: 5006mm (W) x 2225mm (H)

25% Artwork size: 1251.5mm (W) x 556.25mm (H)

Front panel = 732mm/183mm (25%) | 'D' End panel = 673mm/168.25mm (25%)

Please position any text, images or logos used on the 'D' end panels within the side and front sections of the panel avoiding the grey chevron area, as indicated on the diagram.

[Watch our 'how to design artwork' video here](#)

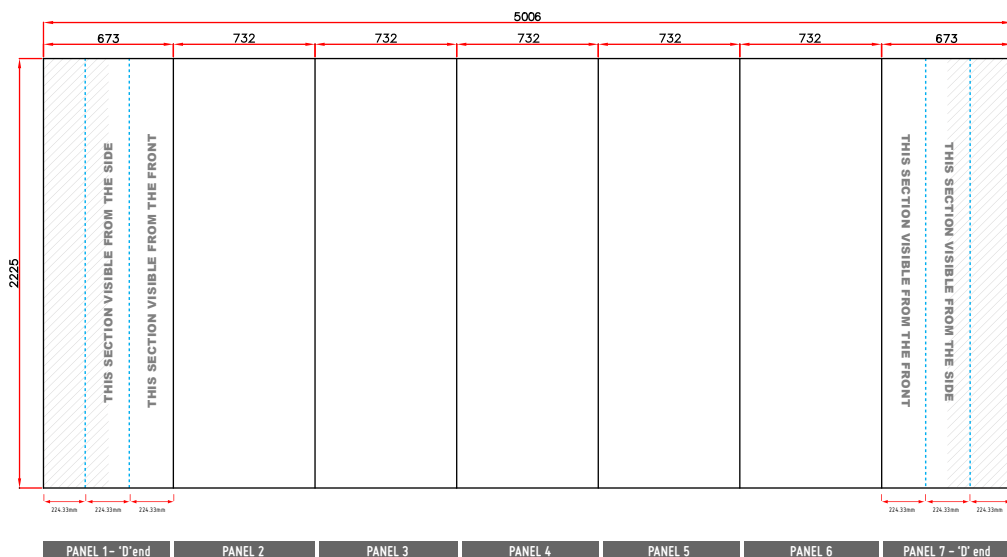
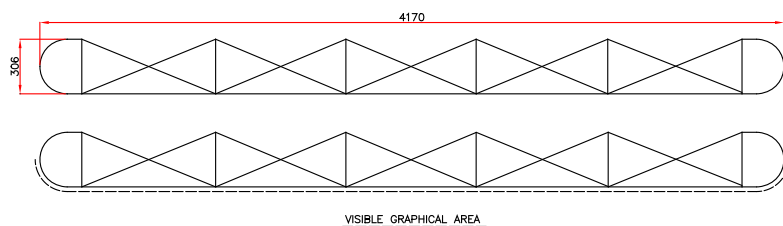

The viewing distance for pop-up displays will be approx 3m, but at least 1m
 According to the file format, colour anomalies may occur
 We print with a tolerance of 0.1 to 0.2% so a difference of 1mm up to 5mm is normal within a height of 230cm

Printing Specification

How to supply your artwork

- We require all artwork to be sent over as a high resolution PDF, 300dpi or higher.
- We do not require any bleed or crop marks, as these will be added on by our software.
- Make sure all of your fonts have been outlined and all of your images and text has been embedded.
- We print in CMYK so make sure all of your images, text and background colours are in CMYK, not RGB.
- We ask for the artwork to be sent over at 25% of the graphic area. This will make the file size for emailing over to us.

What is CMYK?

CMYK stands for Cyan Magenta Yellow and Black (key). CMYK is a colour pattern in which all colours are made up of a mixture of these four colours. CMYK is the standard colour model used in printing, and is often referred to as four-colour printing. CMYK creates each colour by lays a proportion of each colour required to create a colour onto a white background. We recommend using the colour setting **FOGRA39** when creating your PDF to give the best colour match.

Solid black is always an awkward colour to print . In order to achieve solid black please save your files using the following:-

100 C 100 K 100 Y 100 M

What is DPI?

DPI stand for Dots Per Inch. This is used to describe how the quality of an image will printed or shown. The higher the DPI the less pixelated the image will be as the printer will lay more dots per inch for that image, for example an image of 300dpi will have 300 dots of ink per inch whereas a 72dpi image will only have 72 dots per inch.

What is outlining and embedding?

When printing a document the fonts can sometimes cause a problem. If you have used a typeface that we don't have, the document will print without the text. Outlining all the fonts means the text is no longer text and becomes a vector image and the text can no longer be altered. This is similar to embedding, which ensures that any images in the artwork can still be used when this file is opened on another computer or programme even though we do not have the original images. We ask for everything in a file to be embedded to stop any images or text not printing.

What programme should you use to create artwork?

We recommended using either Adobe InDesign or Illustrator to create your artwork as these programmes will allow you to easily create the correct template size you need and save as a PDF. There are many other programmes that are OK to use, as long as you can save your artwork at the correct size in a print-ready format.

Why does the printed artwork look different to the artwork on screen?

When you view your artwork on screen it is showing in RGB (red, green, blue), whereas we print using CMYK (cyan, magenta, yellow, black). RGB has a larger colour range which is perfect for on screen viewing, whereas CMYK is used for printed materials. This is why your artwork will look different on the screen to how it has been printed.

Can I see what the artwork will look like before it goes to print?

We will always print from the exact artwork you provide us and will not change or amend anything without your say so. If we notice something that doesn't look right or is missing we'll come straight back to you. If however you would like to see your artwork on our media to check the colour before we go to print we offer a proofing service, where we will send you a colour proof of your artwork. These are available at an additional cost of £18 and are sent by next day delivery.